

LOLL MAE NEXT NUVOLA COLLECTIONS



GERVASONI

1882

**LOLL, MAE, NEXT, NUVOLA, KIRA,
PAJAMA, BRASS, SILVER, SPIN,
BOLLA, SWEET, ALLU, GHOST, BRICK
COLLECTIONS**

GERVASONI

1882

(I) Un modo di abitare si racconta attraverso una sequenza di luoghi, diversi tra loro ma legati da un'unica sensibilità. Ambienti che cambiano ritmo e atmosfera, in cui arredo e architettura dialogano con naturalezza: spazi raccolti e accoglienti si alternano a volumi essenziali e materici, interni contemporanei si aprono a contesti liberi e informali. Un percorso che restituisce la visione di Gervasoni, capace di adattarsi e trasformarsi senza perdere identità. Al centro del racconto, la collezione di imbottiti Loll, che si evolve offrendo nuove possibilità compositive per l'abitare contemporaneo. Attorno, tavoli, complementi e arredi completano gli spazi con equilibrio, dando forma a un insieme coerente, flessibile e pensato per essere vissuto.

(E) A way of living unfolds through a sequence of places, distinct in atmosphere yet connected by a shared sensibility. Spaces shift in rhythm and mood, where furniture and architecture engage in a natural dialogue: intimate, welcoming settings alternate with more essential, material volumes, while contemporary interiors open onto freer, more informal contexts. A journey that expresses Gervasoni's vision—able to adapt and evolve without losing its identity. At the heart of the narrative is the Loll upholstered collection, evolving to offer new compositional possibilities for contemporary living. Around it, tables, accessories and furnishings complete the spaces with balance, shaping a coherent, flexible whole designed to be lived in.

(F) Une manière d'habiter se dévoile à travers une succession de lieux, différents dans leur atmosphère mais unis par une sensibilité commune. Les espaces changent de rythme et de tonalité, tandis que le mobilier et l'architecture dialoguent avec naturel : des environnements intimes et accueillants alternent avec des volumes plus essentiels et matériels, et des intérieurs contemporains s'ouvrent sur des contextes plus libres et informels. Un parcours qui traduit la vision de Gervasoni, capable d'évoluer et de se transformer sans jamais perdre son identité. Au cœur du récit, la collection de sièges rembourrés Loll évolue en offrant de nouvelles possibilités de composition pour l'habitat contemporain. Autour, tables, compléments et meubles viennent compléter les espaces avec équilibre, donnant naissance à un ensemble cohérent, flexible et pensé pour être vécu.

(D) Eine Art des Wohnens entfaltet sich in einer Abfolge von Räumen, unterschiedlich in ihrer Atmosphäre und doch verbunden durch eine gemeinsame Sensibilität. Die Räume verändern Rhythmus und Stimmung, während Möbel und Architektur in einen natürlichen Dialog treten: intime, einladende Umgebungen wechseln sich mit essenziellen, materiellen Volumen ab, zeitgenössische Interieurs öffnen sich zu freieren, informellen Kontexten. Ein Weg, der die Vision von Gervasoni widerspiegelt – anpassungsfähig und wandelbar, ohne dabei an Identität zu verlieren. Im Mittelpunkt der Erzählung steht die Polstermöbelkollektion Loll, die sich weiterentwickelt und neue kompositorische Möglichkeiten für das zeitgenössische Wohnen eröffnet. Ergänzt wird sie durch Tische, Accessoires und Möbel, die die Räume ausgewogen vervollständigen und ein stimmiges, flexibles Gesamtbild schaffen, das zum Leben gedacht ist.





Index

**1. Sunlit
Living**
p. 006—043

**2. Framed
by Nature**
p. 044—067

**3. Urban
Flow**
p. 068—095

**4. Essential
Volumes**
p. 096—123

**Technical
Informations**
p. 124—151

**Abacus
by Categories**
p. 152—159

Sunlit Living

Chapter 1



007

↓ Loll configuration 01: Divano modulare / Modular sofa in Tweed Barley – D.
Loose cushions: 2 C. Loll PI in Sand Pollara – C; 2 C. Loll XS in Terre de Lin Aretha – B, Terre de Lin Aramis – B.

Bolla 12

Bolla 10

Bolla 15

Loll 14

Loll configuration 01

Brass 44



Loll configuration 01

Bolla 10



Kira 98

Loll 14

Bolla 15

↑ Loll 14: Divano/ Sofa in Tweed Barley - D.



Pajama 95

Bolla M

Bolla 10

Loll 05

Bolla 12

↔ Loll 05: Poltrona/ Armchair
in Arcipelago Patmos - B.



Loll 05

↓ Loll configuration 11: Divano modulare/ Modular sofa in Sand Zingaro - C. Loose cushions: 1 C. Loll Pl in Sand Pollara - C; 3 C. Loll XS in Terre de Lin Aramis - B, Terre de Lin Aretha - B.



Loll configuration 11

Brise 43

Loll 120 R

Brise 44, 46



Brise 44, 46

Loll configuration 11

Brise 43

Daen 85

↑ Loll configuration 11: Divano modulare/ Modular sofa in Sand Zingaro - C.

Loose cushions: 1 C. Loll PI in Sand Pollara - C; 3 C. Loll XS in Terre de Lin Aramis - B, Terre de Lin Aretha - B.



Loll 120 R

↑ Loll 120 R: Elemento modulare/
Modular element in Sand Zingaro - C.
Loose cushion: 1 C. Loll PI in Sand Pollara C.



↓ Loll 128: Pouf/ Ottoman in Movida Almeria - D (stitching 1225 Corda).

↓ Loll 29: Pouf/ Ottoman in Movida Almeria - D (stitching 1225 Corda).

Brass 96

Loll 16

Brise 53

Loll 29

Brise 56

Brise 54

Loll 128



Loll 16

↑ Loll 16: Divano/ Sofa
in Cosmo Marte - C
(stitching 1225 Corda).



Brass 96

Loll 29

Wind L

Brise 54,56

Loll 16

Brise 53



↑← Next 25: Sedia/
Chair in Tweed Rye - D
(stitching 6550 Nero).



Pajama 96

Next 999

Mae 24

Mae 33

↑ Mae 24: Poltroncina dining.
Struttura in frassino laccato nero.
Tessuto: Grande Bouclé Calais - D/
Dining armchair. Black lacquered ash wood
frame. Fabric: Grande Bouclé Calais - D.

↑ Mae 24: Poltroncina dining.
Struttura in frassino laccato nero.
Tessuto: Grande Bouclé Arles - D. /
Dining armchair. Black lacquered ash wood
frame. Fabric: Grande Bouclé Arles - D.

↑ Mae 33: Tavolo ovale
in finitura Ivory/ Oval table
in Ivory finish.





Mae 33

Mae 24

Next 999

030

031

Sunlit Living



Sweet 95

Bolla L, XL

Next 236

Loll 223



↑ Loll 223: Poltroncina dining/
Dining armchair in Sand
Bianca - C (piping 101 caffè).

→ Next 236: Tavolo rotondo.
Base centrale in cemento GFRC.
Piano in marmo bianco Carrara/
Round table. GFRC concrete central
base. Top in white Carrara marble.





Bolla 12

Loll 05

↓← Loll 05: Poltrona/
Armchair in Arcipelago
Hydra - B.



Pajama 91

↓ Loll 80: Letto/ Bed
in Tweed Barley - D
(stitching 6450 Ardesia).

Sweet 91

Loll 07

Heiko 41

Next 999

Loll 80 E



Loll 80 E



↑ Loll 07: Poltroncina/
Armchair in Grande
Bouclé Calais - D.



Loll 07

Heiko 41

Framed by Nature



↓ Loll 09: Poltrona/
Armchair in Bear Polar - D.



Next 142, 144

Loll 09

Pajama 92

Next 141

↓ Ghost 125: Poltroncina dining/ Dining chair in Cosmo Giove - C (stitching 4325 Harley).

↓ Ghost 123: Sedia/ Chair in Sand Mondello - C (stitching 4325 Harley).

↓ Next 136: Tavolo rotondo. Base centrale in fusione di alluminio. Piano in marmo bianco Carrara/ Round table. Cast aluminium central base. White Carrara marble top.





Ghost 125

050



Ghost 123

051

Framed by Nature

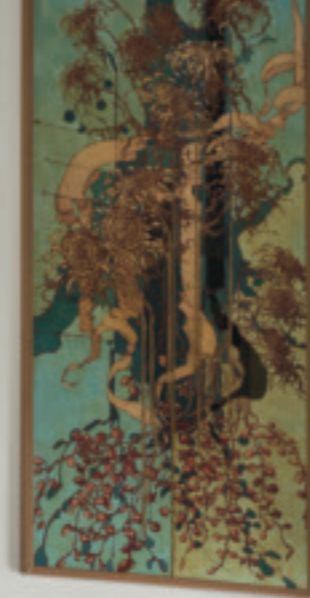

Spin 95



Sweet 97



Log S, M, L



Next 142



Loll 12



Next 144



Loll 128



Next 141





Allu 23 I



Silver 96

Spin S, M

Mae 34

Mae 24



Mae 34



Mae 24

← Mae 34: Tavolo ovale in finitura Graphite/ Oval table in Graphite finish.

↑ Mae 24: Poltroncina dining. Struttura in frassino laccato nero. Tessuto: Deus Pegaso - C/ Dining armchair. Black lacquered ash wood frame. Fabric: Deus Pegaso - C.



↓ Loll configuration 13: Divano modulare/ Modular sofa in Mountains Latemar - C.

Loose cushions: 1 C. Loll PI in Sand Zingaro - C; 2 C. Loll XS in Grande Bouclé Nantes - D.

Pajama 94

Heiko 43

Heiko 41

Loll configuration 13

Heiko 44

Kira 46

→ Loll 09: Poltrona/
Armchair in Bear Polar - D.



Kira 43, 44, 46



Kira 46

Loll 09

Kira 43

Heiko 41, 43, 44



Pajama 95

Loll 225

Mae 33

↑ Mae 33: Tavolo ovale
in finitura Ferro/ Oval table
in Ferro finish.

↑ Loll 225: Poltroncina dining/
Dining chair in Grande Bouclé
Lille - D.



Pajama 95

Loll 225

Mae 33

Urban Flow



↓ Loll configuration 10: Divano modulare/ Modular sofa in Galassia Sirio - D.

Loose cushions: 2 C. Loll PI in Galassia Arturo - D, Sand Majore - C; 2 C. Loll XS in Galassia Arturo - D, Sand Majore - C.



Sweet 98



Loll configuration 10



Kira 46



Loll 08



Loll 09

→ Loll 09: Poltrona/ Armchair
in Grande Bouclé Limoges - D.

→ Loll 08: Pouf/ Ottoman
in Grande Bouclé Limoges - D.



Kira 43

Loll 09

Loll 08



↓ Loll configuration 17: Divano modulare/ Modular sofa in Tweel Till - C.

Loose cushion: 1 C. Loll XS in Grande Bouclé Nantes - D.

Spin M, L

Kira 43

Kira 44, 46

Loll configuration 17

Next 999



Loll configuration 17



Kira 44, 46



Kira 97

Silver 96

Brick 143

Loll 226

Loll 225



↓ Loll 225: Poltroncina dining/
Dining chair in Grande Bouclé
Reims - D.

↓ Loll 226: Poltroncina dining/
Dining chair in Grande Bouclé
Reims - D.

Loll 225



Brick 143

↑ Brick 143: Tavolo rettangolare. Rectangular table. Legs in
Gambe in porcellana bianca e sabbia vulcanica. Piano in
white porcelain and volcanic sand. Lava stone top.
pietra lavica/



Sweet 96

Log S, M

Loll 07

Loll 223

Loll 224

Mae 36

↑ Mae 36: Tavolo rotondo
in finitura Cenere/ Round table
in Cenere finish.

↑ Loll 224: Poltroncina dining/
Dining armchair in Galassia
Altair - D.

↑ Loll 223: Poltroncina dining/
Dining armchair in Galassia
Altair - D.

↑ Loll 07: Poltrona/ Armchair
in Movida Arrecife - D.



084



Loll 224

085

Urban Flow



Kira 98

Log S, M

Heiko 43

Nuvola 12

Heiko 44

Nuvola 09

↑ Nuvola 12: Divano/
Sofa in 3D Blu - E.

↑ Nuvola 09: Poltrona/
Armchair in 3D Blu - E.



Nuvola 09

↓ Loll configuration 12: Divano
modulare/ Modular sofa
in Cosmo Nettuno - C.

Loose cushions: 2 C. Loll PI in
Artist Picasso - C; 2 C. Loll XS in
Artist Monet - C, Deus Ade - C.

↓ Loll 128: Pouf/ Ottoman
in Cosmo Nettuno - C.



Spin S, M

Bolla 12

Loll 128

Loll configuration 12



Loll configuration 12



Loll 225

Brass 147

Loll 226

↑ Loll 225: Poltroncina dining/ Dining armchair in Grande Bouclé Nantes - D.
 ↑ Loll 226: Poltroncina dining/ Dining armchair in Grande Bouclé Nantes - D.



Sweet 98

Loll 223

Loll 224

Brass 146

↑ Loll 223: Poltroncina dining/ Dining armchair in Galassia Altair - D.

↓ Loll 224: Poltroncina dining/ Dining armchair in Galassia Altair - D.

Essential Volumes



↓ Loll configuration 06: Divano modulare/ Modular sofa in Sand Marinella - C.

Loose cushions: 2 C. Loll PI in Movida Cadice - D, Movida Santander - D; 4 C. Loll XS in Movida Cadice - D, Grande Bouclé Toulouse - D, Cosmo Saturno - C.



Kira 43, 44

Loll configuration 06

Heiko 44

Kira 97

Kira 46



↓ Loll configuration 14:
Modular sofa/ Divano modulare
in Grande Bouclé Calais - D.

Loose cushions: 4 C. Loll PI
in Galassia Canopo - D, Terre
de Lin Melina - B; 1 C. Loll XS
in Terre de Lin Vesta - B.



Loll configuration 14

Brass 44

Heiko 43, 44

Loll 136 R

Brass 43

↓ Loll 136 R: Elemento
modulare/ Modular element
in Grande Bouclé Lille - D.

Loose cushion: 1 C. Loll XS
in Movida Bilbao - D.



Daen 72

Loll 136 R



Brass 44

↓ Nuvola 12: Divano/
Sofa in 3D Grigio - E.

↓ Nuvola 05: Poltrona/
Armchair in 3D Grafite - E.



Pajama 91

Nuvola 12

Heiko 44

Nuvola 05

Brass 43





↓ Brick 143: Tavolo rettangolare.
Gambe in porcellana colore celadon.
Piano in marmo bianco Carrara/
Rectangular table. Legs in celadon
porcelain. White Carrara marble top.





Loll configuration 16

Next 147, 148

Loll configuration 15

↓ Loll configuration 15: Divano modulare/ modular sofa in Tweel Quair - C.

Loose cushions: 1 C. Loll PI in Galassia Canopo - D; 1 C. Loll XS in Terre de Lin Alizee - B.

↓ Loll configuration 16: Divano modulare/ modular sofa in Tweel Quair - C.



Loll configuration 16



Loll 01

Kira 44

Kira 46



← Loll 01: Poltrona/ Armchair
in Mountains Cimone - C
(stitching 7175 Pink).

Loose cushion: 1 C. Loll XS
in Tweed Sunset - D.



Spin 96

Ghost 125

Next 137

↑ Next 137: Tavolo ovale, Base centrale in fusione di alluminio. Piano in marmo bianco Carrara/ Oval table. Cast aluminium central base. White Carrara marble top.

↑ Ghost 125: Sedia/ Chair in Mountains Cervino - C (stitching 2375 Corteccia).



Ghost 125





Technical Info

I. La bellezza della semplicità e il comfort prendono forma nella collezione Loll. Composta da divani e poltrone accoglienti e confortevoli, Loll racconta un'idea di comfort contemporaneo, reso speciale dalla cura dei dettagli, dalla qualità dei materiali e dall'unicità della lavorazione artigianale. Il profilo dei divani è sottolineato dalla caratteristica taglia / cucì che, come un tratto leggero disegnato a mano libera, segue le geometrie essenziali e le linee morbide della collezione.

E. The beauty of simplicity and comfort take shape in the Loll collection. Composed of cosy and comfortable sofas and armchairs, Loll tells a story of contemporary comfort, made special by the attention to detail, the quality of the materials and the uniqueness of the craftsmanship. The profile of the sofas is underlined by the characteristic overlock-stitching which, like a light line drawn by hand, follows the essential geometries and soft lines of the collection.



F. La beauté de la simplicité et le confort prennent forme dans la collection Loll. Composée de canapés et de fauteuils accueillants et confortables, Loll raconte une idée de confort contemporain, qui est rendu spécial grâce à l'attention portée aux détails, à la qualité des matériaux et au caractère unique de l'artisanat. Le profil des canapés est rehaussé par des surpiqûres qui, tel un tracé léger et dessiné à la main, suivent les géométries essentielles et les lignes douces de la collection.

D. Schmucklose Schönheit und Komfort nehmen in der Kollektion Loll Form an. Die aus bequemen Sofas und Sesseln bestehende Kollektion Loll erzählt von modernem Komfort, der durch Detailgenauigkeit, Materialqualität und eine einzigartige handwerkliche Verarbeitung besonders wird. Das Profil der Sofas wird durch die charakteristische Overlocknaht unterstrichen, die wie freihändig flink der minimalistischen Geometrie und den weichen Linien der Kollektion folgen.

Loll Section

A →
Struttura / Structure /
Structure / Gestell

Struttura in legno massello preparata con poliuretano espanso a quote differenziate, localizzate, ad alta densità, al fine di migliorarne comfort, sofficià e durata. Rivestimento della struttura in fibra termolegata traspirante accoppiata con una maglia elastica bianca che ne conferisce maggior morbidezza. Piedi in polietilene ad alta resistenza, colore nero.

Structure in solid wood made of high resilience, variable-density polyurethane foam, in order to improve comfort, softness and durability. Structure covered with breathable, heat-bonded fiber laminated to white elastic jersey which gives it greater softness. Circular feet in high resistance black polyethylene.

Structure en bois massif associée à du polyuréthane expansé à densité différenciée haute résilience, garantissant confort, souplesse et longévité. Revêtement de la structure en fibre thermocollée respirante, doublée de jersey élastique blanc qui lui confère une plus grande douceur. Pieds circulaires en polyéthylène haute résistance, couleur noire.

Gestell aus Massivholz, Polsterung des Gestells der Sitzfläche aus PU-Schaum mit differenzierter, hoher Dichte, um Komfort, Weichheit und Langlebigkeit zu verbessern. Die Polsterung mit atmungsaktiver temperaturregulierter Faser sorgt zusammen mit dem elastischen weißen Stoff für eine große Weichheit. Runde FüÙe aus hochwiderstandsfähigem Polyethylen, schwarze Farbe.

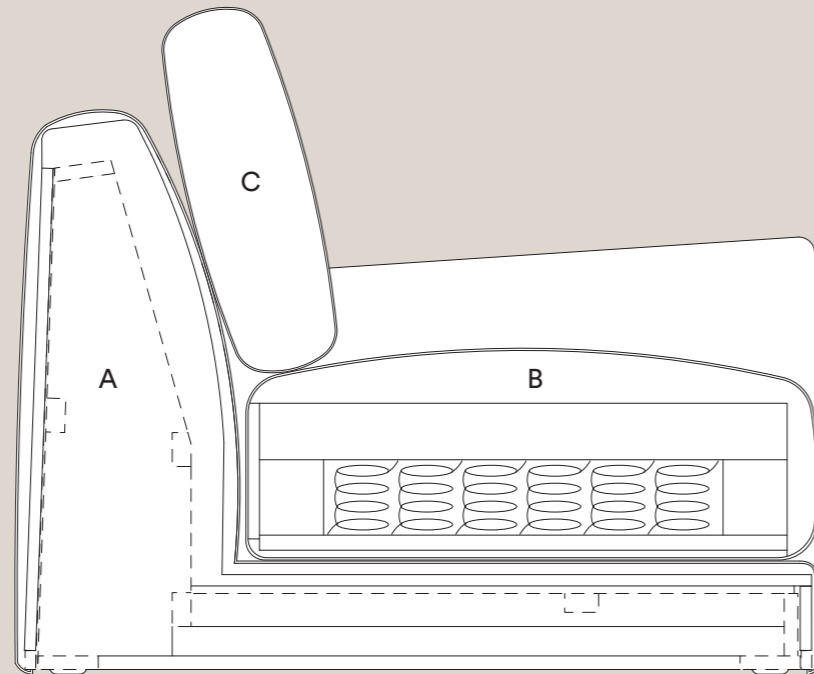

B → Imbottitura / Upholstery /
Garnissage / Füllung

I cuscini di seduta sono realizzati in piuma d'oca canalizzata (certificata Assopioma) con inserto centrale in poliuretano espanso a quote differenziate ad alta resilienza e molle insacchettate.

Seat cushions in channeled goose down (Assopioma certified) with core insert in high-resilience, variable-density polyurethane foam and independent pocket springs.

Coussins d'assise en plume d'oie cloisonnée (certifiée Assopioma) avec insert central en polyuréthane expansé à densité différenciée haute résilience et ressorts ensachés.

Sitzkissen mit gesteppter Gänseadaunenfüllung mit Kammern und Innenstegen (zertifiziert Assopioma), mit Kern aus hochwiderstandsfähigem PU-Schaum mit differenzierter Dichte und Taschenfederkern.

C → Cuscini / Cushions /
Coussins / Kissen

I cuscini di schienale sono realizzati in piuma d'oca canalizzata (certificata Assopioma) e fibra di poliestere.

Backrest cushions in channeled goose down (Assopioma certified) and polyester fibers.

Coussins de dossier en plume d'oie cloisonnée (certifiée Assopioma) et fibres de polyester.

Die Rückenkissen sind mit kammergefüllter Gänseadaune (Assopioma-zertifiziert) und Polyesterfasern gepolstert.

Sfoderabilità / Covers /
Déhoussage / Abziehbarkeit

I cuscini del sedile, dello schienale e la struttura sono completamente e facilmente sfoderabili a garanzia di una facile e frequente pulizia del rivestimento.

Structure, seat and backrest cushion covers are completely and easily removable in all versions, to guarantee easy and frequent cleaning of the covers.

Structure, coussins d'assise et de dossier entièrement et facilement déhoussables dans toutes les versions, permettant un lavage aisé et fréquent du tissu.

Gestell, Sitzkissen und Rückenkissen sind in allen Versionen komplett abziehbar, was eine einfache und häufige Reinigung der Bezüge garantiert.

Loll 01 → p. 118-119

Loll 05 → p. 012, 013, 036

Loll 07 F/G → p. 039, 041, 042-043, 083

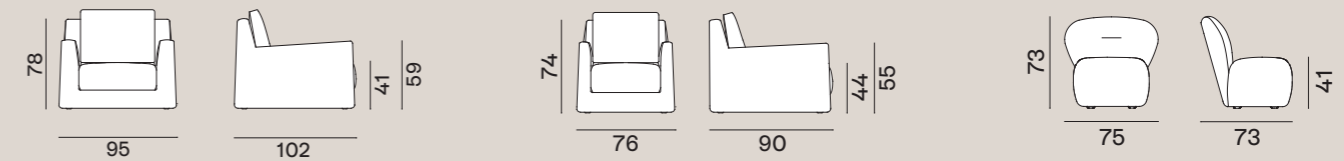

Loll 08 → p. 071, 073

Loll 09 F/G → p. 046-047, 063, 071, 073

Loll 10

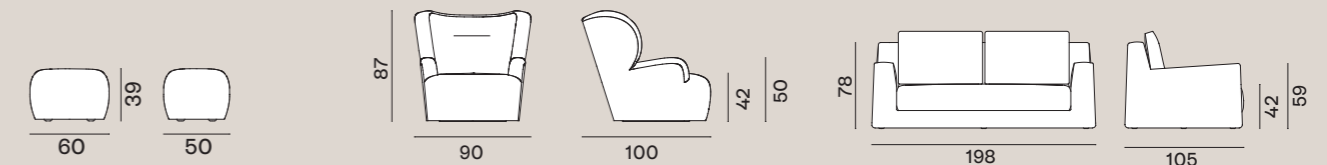

Loll 10 G

Loll 12 → p. 052-053



Loll 14 → p. 011

Loll 16 → p. 020, 022, 023



Loll 128 → p. 021, 053, 061, 091

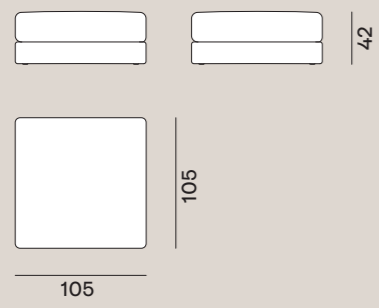

Loll 29 → p. 021

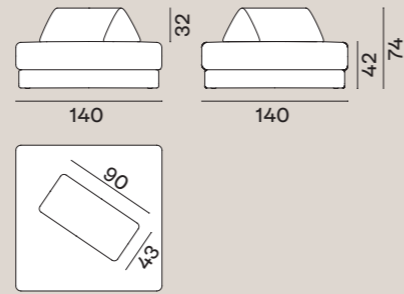

Loll 80 → p. 038-039, 040

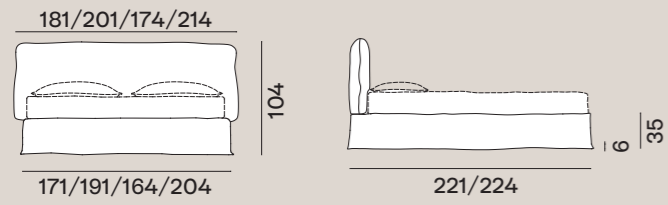

Loll 120 L-R → p. 015, 019

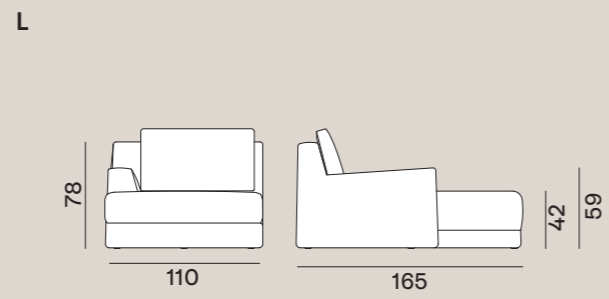

Loll 121 L-R

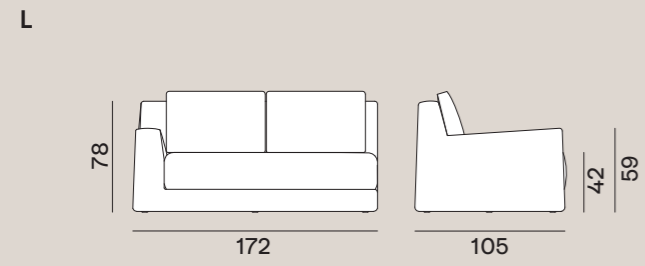

Loll 122 L-R

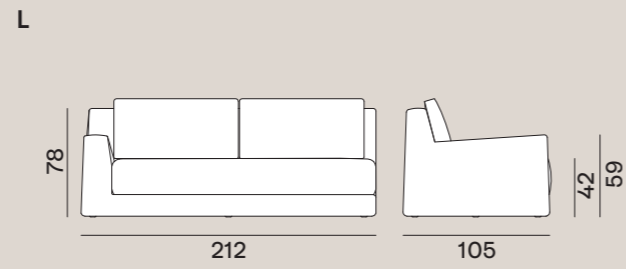

Loll 123

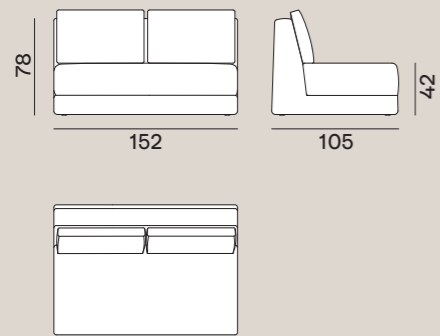

Loll 125 AN

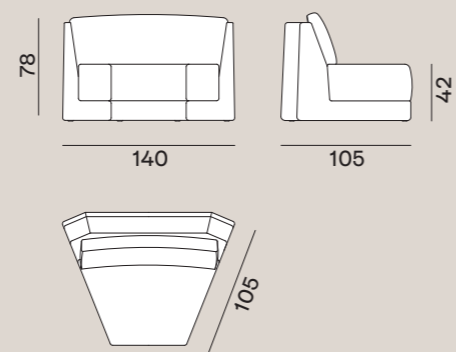

Loll 126 AN

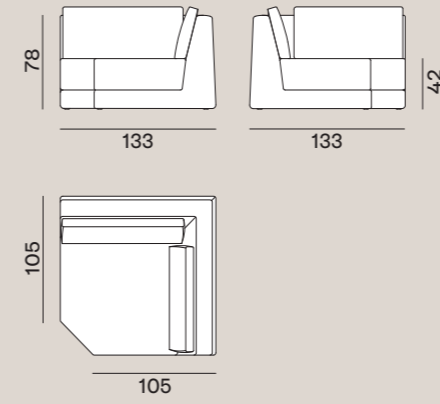

Loll 127 AN

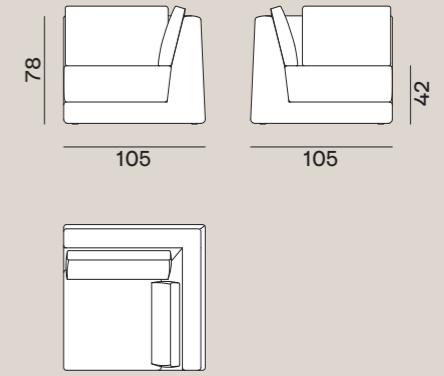

Loll 130 L-R

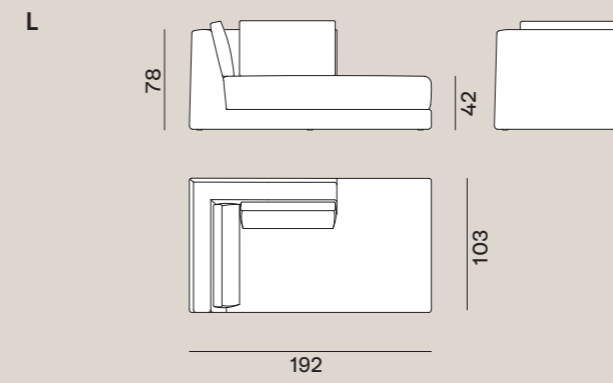

Loll 131 L-R

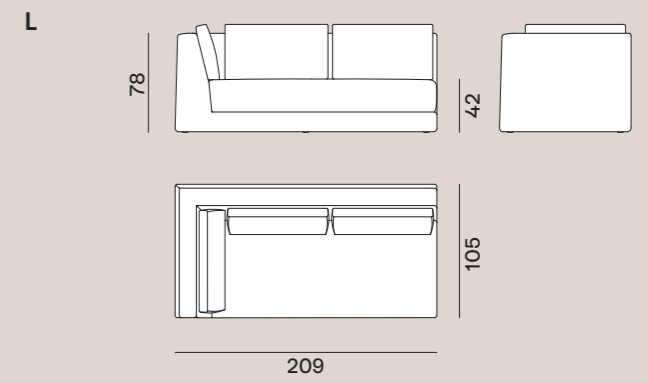

Loll 132 L-R

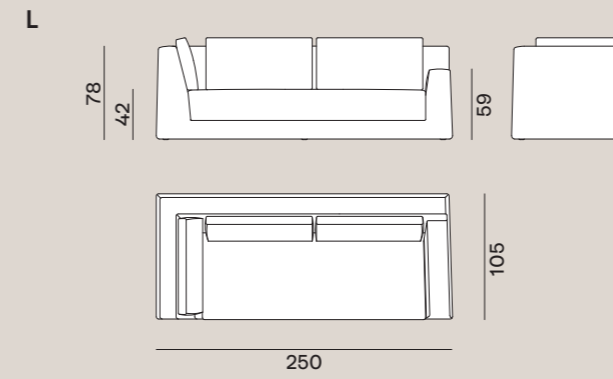

Loll 134

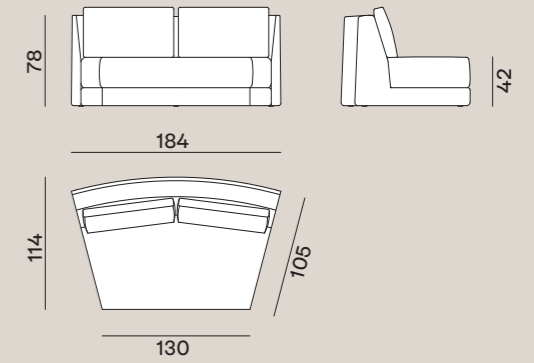

Loll 135 L-R

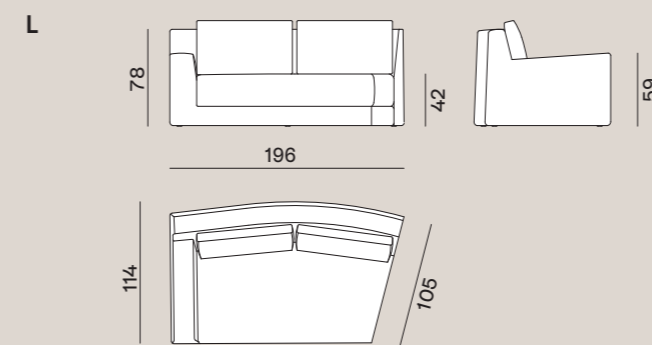

Loll 136 L-R → p. 102, 104

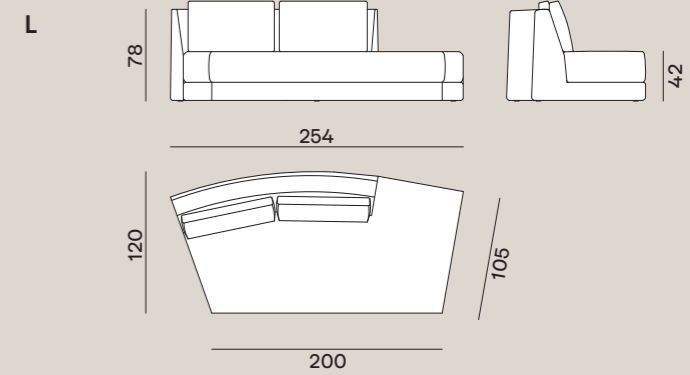

Loll 138 L-R

Loll 223 → p. 032-033, 034, 083, 095

L

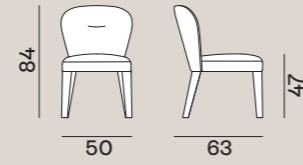
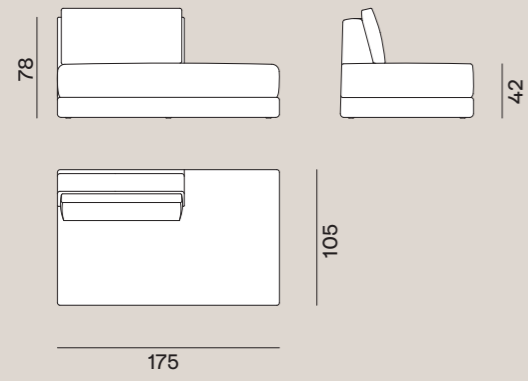

Loll 224 → p. 082, 084, 085, 095

Loll 225 → p. 064-065, 067, 078-079, 094

Loll 226 → p. 078-079, 094

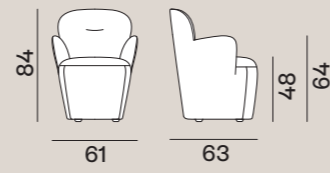
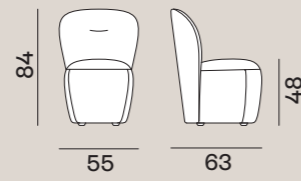
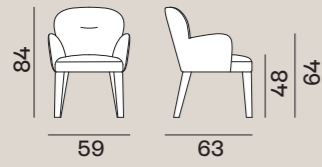

C. Loll PI

C. Loll XS

C. Loll XL

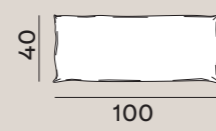
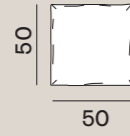
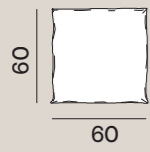

Loll Configuration 01 → p. 008-009, 010

Loll Configuration 02

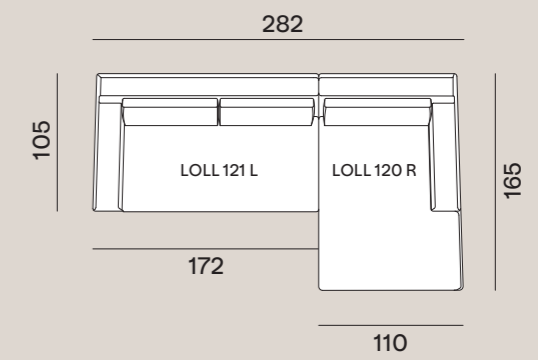
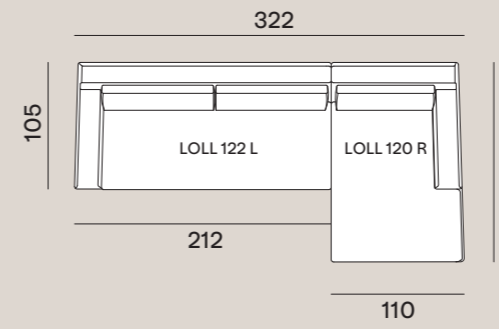

Loll Configuration 03

Loll Configuration 04

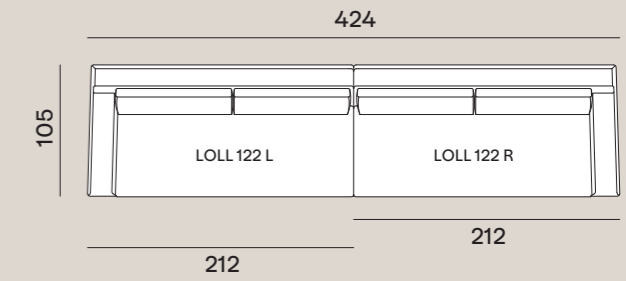
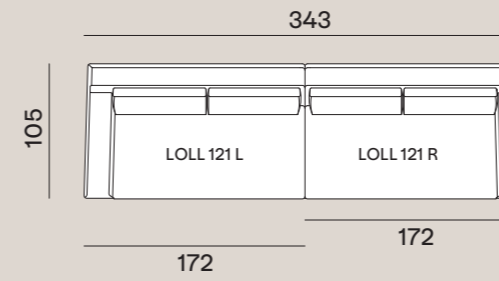

Loll Configuration 05

Loll Configuration 06 → p. 098-099, 101

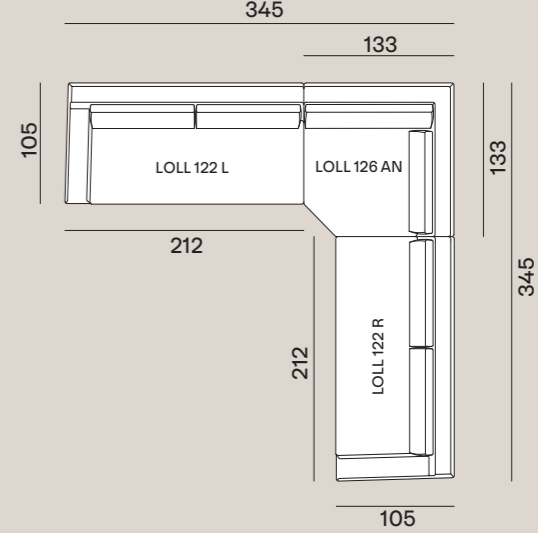
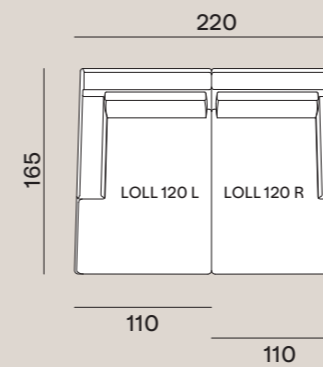

Loll Configuration 07

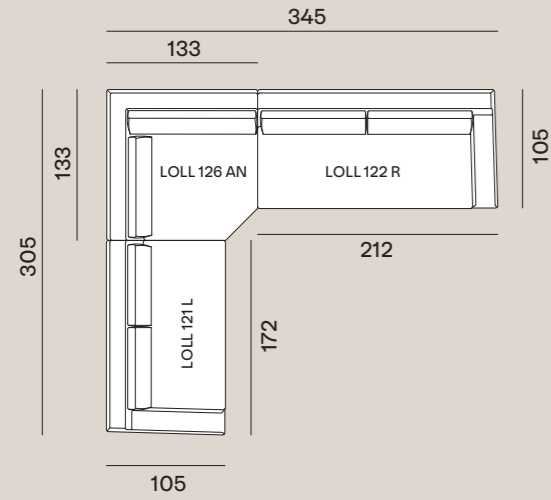

Loll Configuration 08

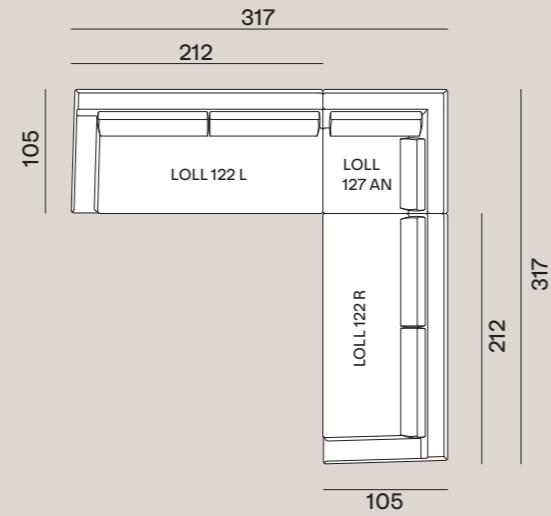

Loll Configuration 09

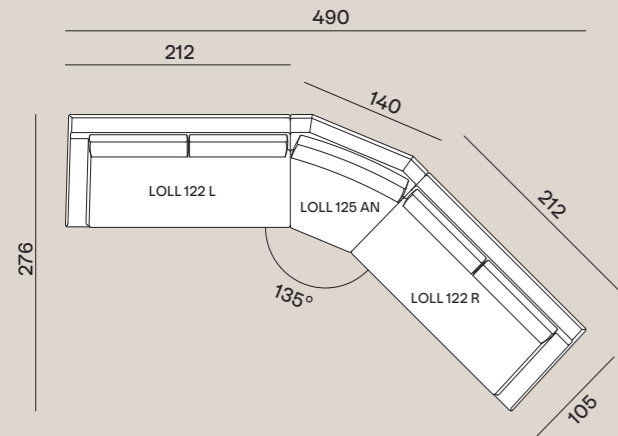

Loll Configuration 10 → p. 070-071

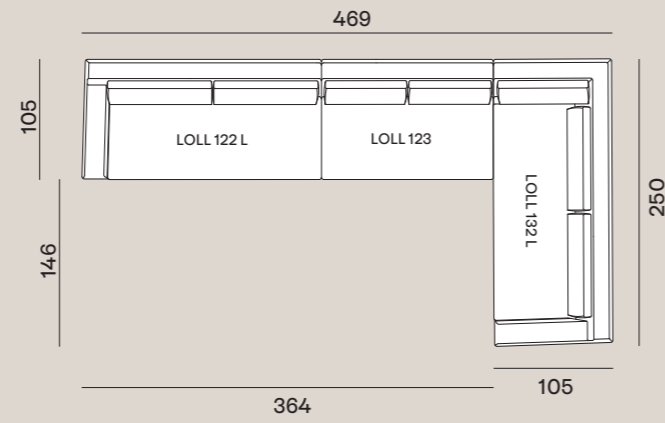

Loll Configuration 11 → p. 014-015, 016, 018

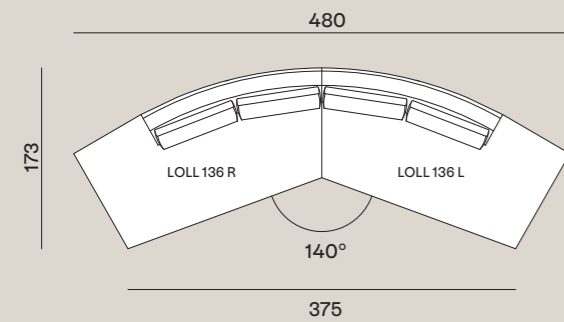

Loll Configuration 12 → p. 090-091, 092-093

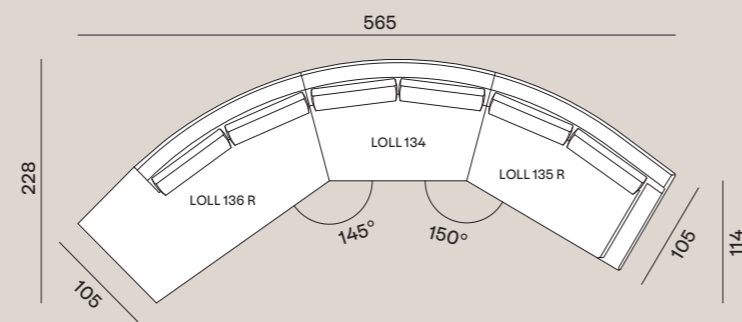

Loll Configuration 13 → p. 060-061

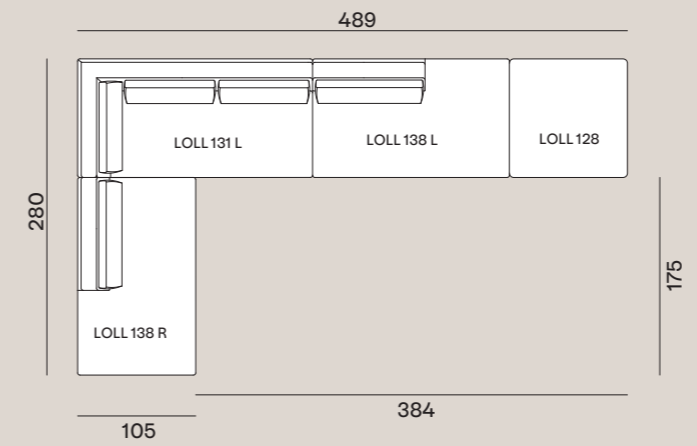

Loll Configuration 14 → p. 102-103

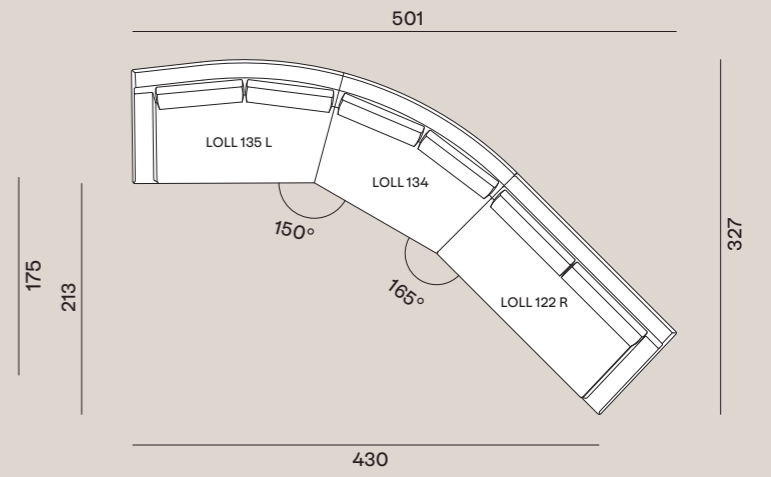

Loll Configuration 15 → p. 115, 116-117

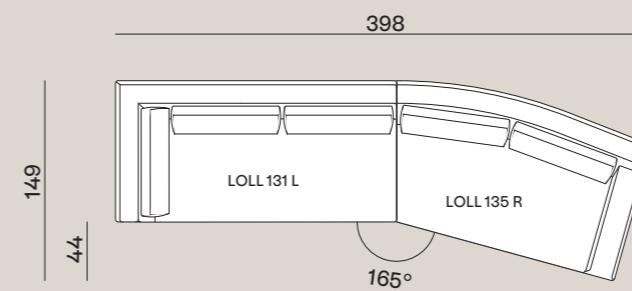

Loll Configuration 16 → p. 114, 116-117

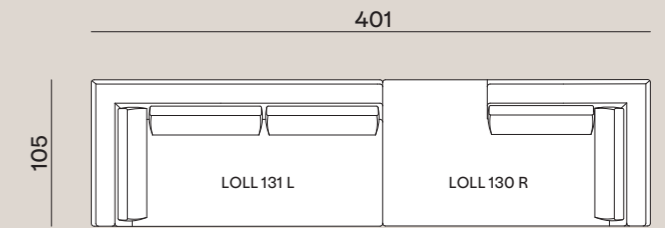

Loll Configuration 17 → p. 074-075

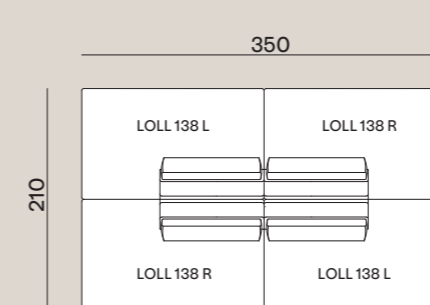

I. Forme semplici e raffinate che si esaltano negli inediti abbinamenti di materiali caratterizzano Next, collezione di arredi dedicati al living e alla zona dining. Dai tavoli scultorei con base di cemento GFRC, ai tavoli e tavolini con basi in fusione di alluminio, ogni elemento assume, a seconda degli abbinamenti di materiali e finiture, un aspetto sempre diverso, classico, essenziale o pop.

E. Simple yet refined forms, enhanced by original material pairings, define Next, a furniture collection designed for the living and dining areas. From sculptural tables with GFRC concrete bases to tables and side tables with cast aluminum bases, each element takes on a different character depending on the combinations of materials and finishes — classic, essential, or pop.

F. Des formes simples et raffinées, sublimes par des associations de matériaux inédites, caractérisent Next, une collection de mobilier dédiée au séjour et à l'espace repas. Des tables sculpturales à base en béton GFRC aux tables et tables basses présentant des bases en fonte d'aluminium, chaque élément adopte, selon les matériaux et finitions choisis, une esthétique toujours différente — classique, essentielle ou pop.

D. Einfache und raffinierte Formen, die durch neuartige Materialkombinationen zur Geltung kommen, kennzeichnen Next, eine Einrichtungskollektion für den Wohn- und Essbereich. Von skulpturalen Tischen mit GFRC-Betonsockel bis hin zu Tischen und Beistelltischen mit Füßen aus Aluminiumguss erhält jedes Element – je nach Materialkombination und Finish – stets ein anderes Erscheinungsbild: klassisch, minimalistisch oder pop.



Struttura / Structure



Alluminio
Aluminium

Next 141 → p. 046-047, 052-053

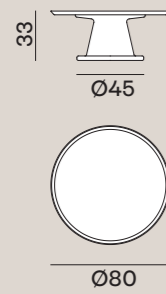

Next 142 → p. 046-047, 052-053

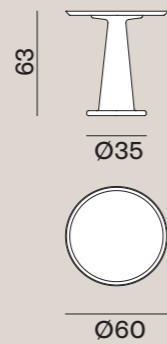

Next 144 → p. 046-047, 052-053



Next 147 → p. 114-115

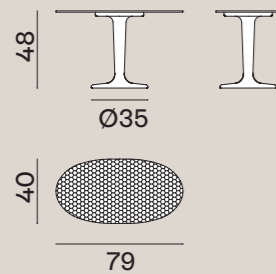

Next 148 → p. 114-115

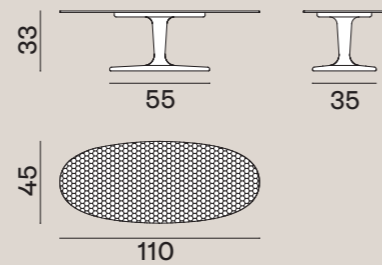

Piano Tavolo / Table Top

Base Tavolo / Table Base



Marmo Bianco
White Marble



Fusione Alluminio
Cast Aluminium

Finiture Legno / Wood Finishes
Next 25



Next 25 → p. 024, 025
* Solo finiture legno / Only wood finishes

Next 132

Next 136 → p. 048-049

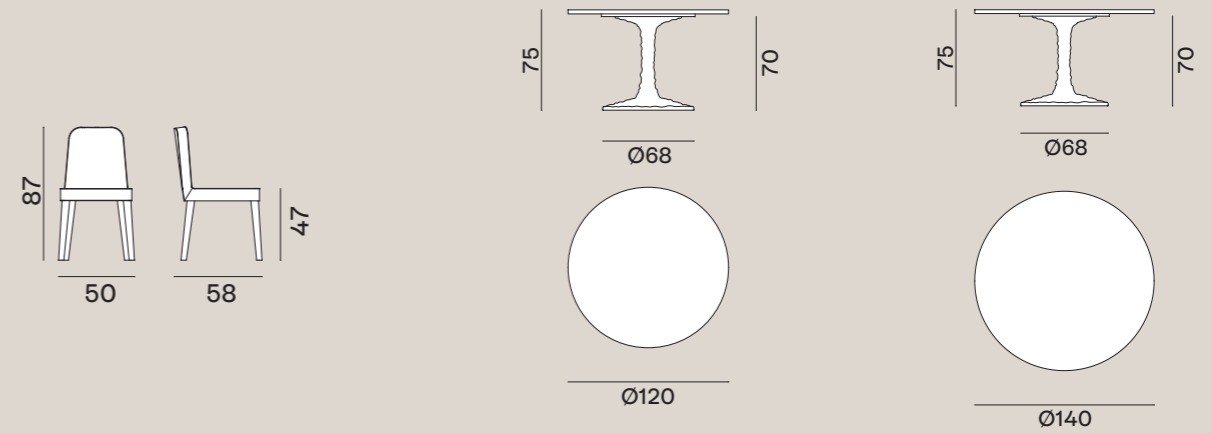

Next 137 → p. 120-121

Next 138

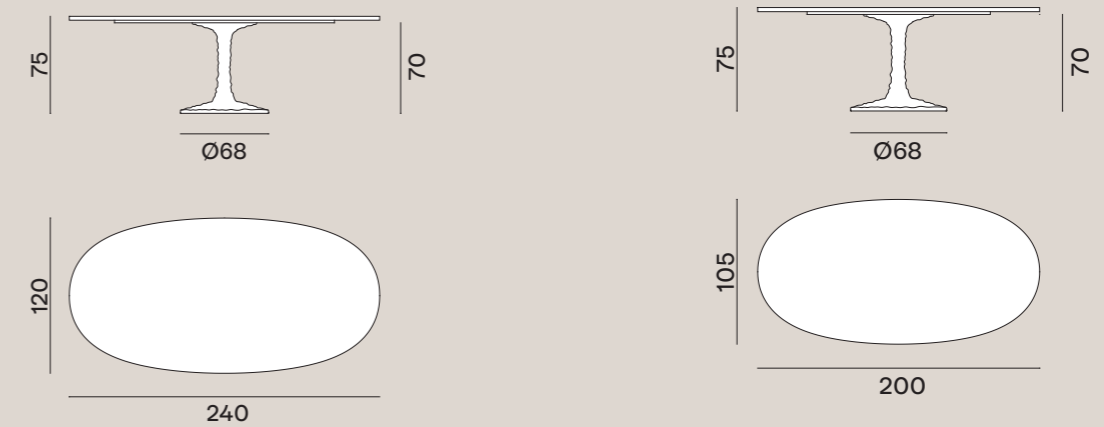

Piano Tavolo / Table Top

Base Tavolo / Table Base



Marmo Bianco
White Marble



Cemento GFRC
GFRC Concrete

Next 232

Next 236 → p. 032-033, 035

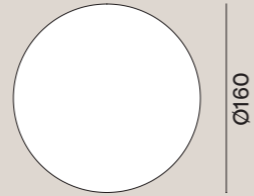
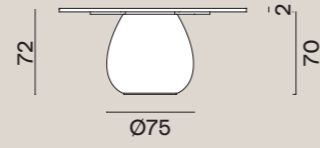
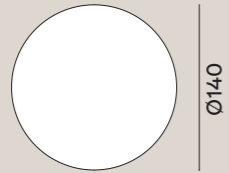
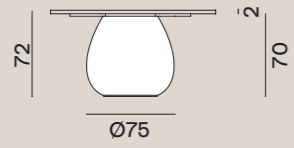

Tappeti / Carpets



Silver

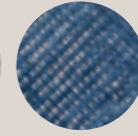

Blue



Slate



Brown

Next 998

Next 999 → p. 026-027, 038, 058, 074-075, 110

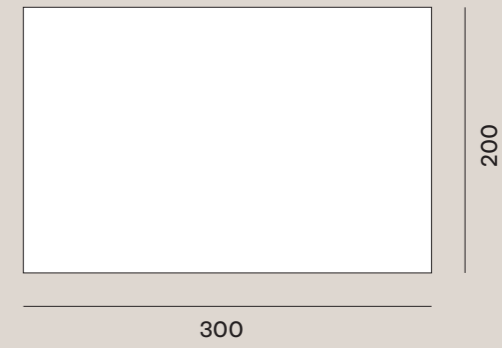
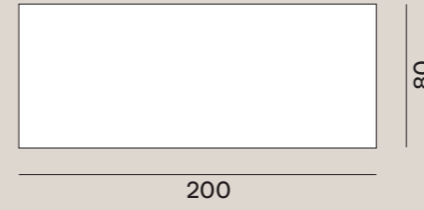

I. Nuvola è una collezione di imbottiti, composta da poltrone e divani, che si contraddistingue per le sue forme soffici e attraenti. Un imbottito oversize dall'aria informale, completamente sfoderabile, che cambia look a seconda del rivestimento scelto.

F. Nuvola est une collection de meubles d'assise rembourrés, composée de fauteuils et de canapés qui se distinguent par leurs formes douces et séduisantes. Une assise rembourrée et oversize au style informel, dont la housse est entièrement amovible et change d'aspect en fonction du revêtement choisi.

E. Nuvola is a collection of upholstered seating, comprising armchairs and sofas, defined by soft, inviting shapes. An oversized design with an informal feel, fully removable, that changes its look according to the selected upholstery.

D. Nuvola ist eine Kollektion von Polstermöbeln, bestehend aus Sofas und Sesseln, die sich durch die weichen und einladenden Formen auszeichnen. Die komplett abziehbaren Oversize-Polstermöbel mit lässigem Charakter ändern je nach Bezug ihr Aussehen.



Nuvola Section

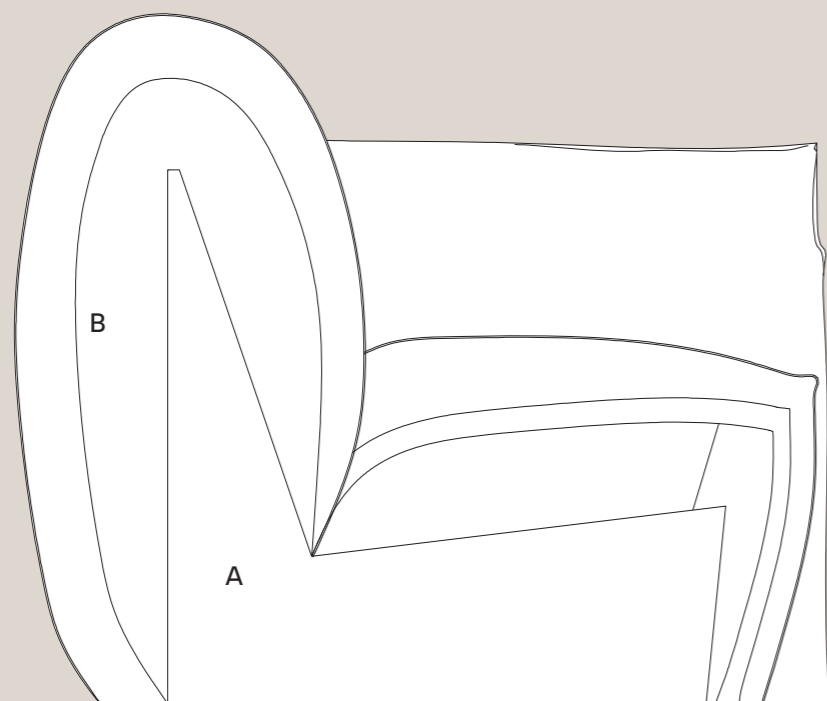

A → Struttura / Structure / Structure / Gestell

I. La struttura interna della seduta e dello schienale è realizzata in multistrati e masselli di abete.

E. The internal structure of the seat and backrest is made of solid fir wood and multilayer panels.

F. La structure interne de l'assise et du dossier est réalisée en multiplis et en bois massif de sapin.

D. Das Sitz- und Rückengestell besteht aus Multischicht- und Massivtannenholz.

B → Imbottitura / Upholstery / Garnissage / Füllung

I. L'imbottitura in poliuretano espanso è rivestita con trapuntino imbottito con piuma d'oca e fiocco di fibra di poliestere.

E. The padding is made of polyurethane foam, covered with a quilted layer filled with goose down and polyester fiber.

F. Rembourrage en mousse polyuréthane avec couche matelassée en duvet d'oie et fibres de polyester.

D. Polsterung aus Polyurethanschaum, Weißpolsterbezug gefüllt mit Daunen und Polyesterflöckchen.

→ Sfoderabilità / Covers / Déhoussage / Abziehbarkeit

I. Struttura completamente e facilmente sfoderabile a garanzia di una facile e frequente pulizia del rivestimento.

E. Cover completely and easily removable to guarantee easy and frequent cleaning.

F. Elements entièrement et facilement déhoussables permettant un lavage aisé et fréquent du tissu.

D. Komplett abziehbare Elemente, was eine einfache und häufige Reinigung der Bezüge garantiert.

Nuvola 05 → p. 107, 108, 109

Nuvola 09 → p. 086-087, 089

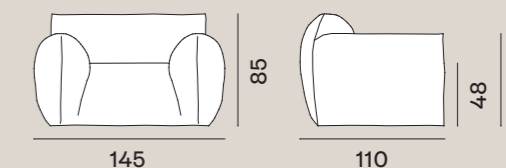
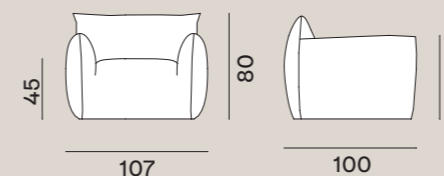

Nuvola 10

Nuvola 12 → p. 086-087, 088, 106-107

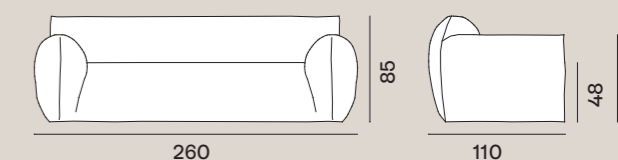
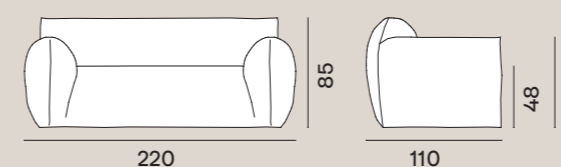

I. Un intreccio armonioso e curve sinuose contraddistinguono la collezione Sweet. Saperi artigianali di antica tradizione si combinano a materiali contemporanei dando vita a lampade e specchi dal look accattivante che conferiscono ad ogni ambiente indoor grande forza espressiva.

E. A harmonious interplay and sinuous curves define the Sweet collection. Traditional craftsmanship rooted in time-honoured know-how combines with contemporary materials to create lamps and mirrors with a striking appeal, bringing strong expressive character to any indoor space.

F. La collezione Sweet se distingue par un tissage harmonieux et des courbes sinueuses. Le savoir-faire artisanal issu de traditions anciennes se combine à des matériaux contemporains, donnant ainsi vie à des lampes et des miroirs au style captivant, qui confèrent à chaque espace intérieur une grande force expressive.

D. Harmonische Verflechtungen und üppige Formen kennzeichnen die Kollektion Sweet. Handwerk nach antiker Tradition verbindet sich mit modernen Materialien und haucht Lampen und Spiegeln mit ansprechendem Aussehen Leben ein, die jedem Innenbereich große Ausdrucksstärke verleihen.



Intreccio / Weaving

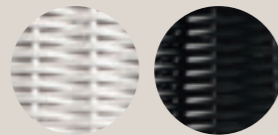

Bianco lucido
Glossy white

Nero opaco
Matt black

Decoro specchi / Mirror decoration



Bianco
White

Nero
Black

Sweet 91 → p. 038

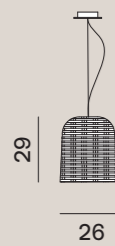

Sweet 95 → p. 032-033

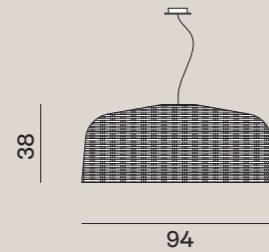

Sweet 96 → p. 082-083

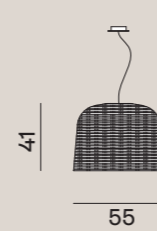

Sweet 97 → p. 053

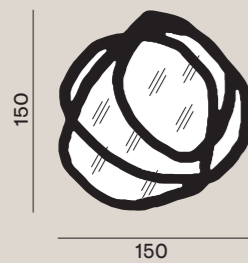

Sweet 98 → p. 070, 095

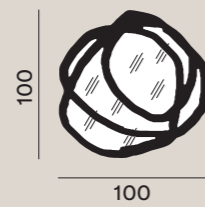

I. Collezione di tavolini in alluminio fuso con texture superficiale irregolare. Ogni tavolino presenta una struttura monolitica con base rettangolare e piano con vano cavo, ed è disponibile in tre dimensioni e due finiture. La collezione comprende inoltre due specchi, uno ovale e uno tondo, realizzati con blocchi distanziatori in alluminio fuso lucidato.

E. Collection of coffee tables in cast aluminum with an irregular surface texture. Each table features a monolithic structure with a rectangular base and a top with a hollow compartment, and is available in three sizes and two finishes. The collection also includes two mirrors, one oval and one round, made with polished cast aluminum spacer blocks.

F. Collection de tables basses en aluminium moulé avec une texture de surface irrégulière. Chaque table présente une structure monolithique avec une base rectangulaire et un plateau avec un compartiment creux, et est disponible en trois dimensions et deux finitions. La collection comprend également deux miroirs, un ovale et un rond, réalisés avec des blocs entretoises en aluminium moulé poli.

D. Kollektion von Beistelltischen aus Aluminiumguss mit unregelmäßiger Oberflächenstruktur. Jeder Tisch zeichnet sich durch eine monolithische Struktur mit rechteckigem Sockel und einer Platte mit Hohlraum aus und ist in drei Größen und zwei Ausführungen erhältlich. Zur Kollektion gehören außerdem zwei Spiegel, ein ovaler und ein runder, mit Abstandshaltern aus poliertem Aluminiumguss.



Finiture tavolini / Side tables finishes

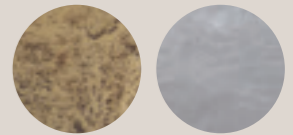

Gold

Chrome

Kira 43 → p. 062, 063, 073, 074, 100

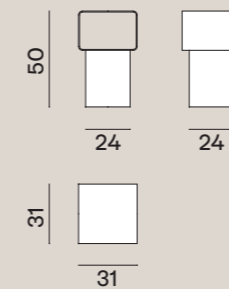

Kira 44 → p. 062, 063, 075, 077, 100, 118

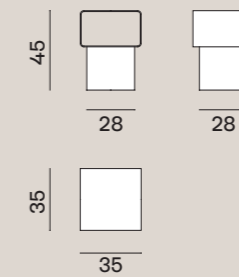

Kira 46 → p. 061, 062, 063, 071, 075, 077, 099, 118

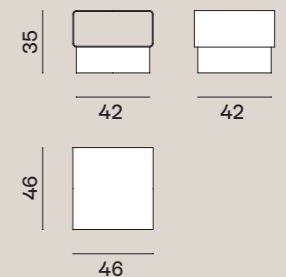

Kira 97 → p. 029, 079, 098-099

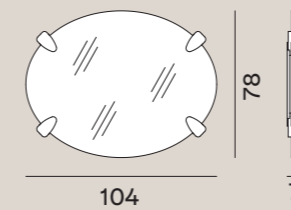

Kira 98 → p. 011, 086

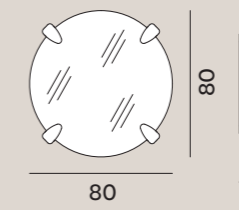

I. Collezione di lampade da terra e a sospensione in Tyvek®. Le lampade da terra hanno una base interna in resina e una struttura paralume in metallo. Le sospensioni presentano un paralume con struttura metallica, rosone e cavo rivestiti in Tyvek®.

E. Collection of floor and pendant lamps in Tyvek®. The floor lamps feature an internal resin base and a metal shade structure. The pendant lamps have a metal shade structure, with a canopy and cable covered in Tyvek®.

F. Collection de lampes sur pied et suspendues en Tyvek®. Les lampes sur pied ont une base interne en résine et une structure d'abat-jour en métal. Les suspensions présentent une structure d'abat-jour en métal, avec un pavillon et un câble recouverts de Tyvek®.

D. Kollektion von Steh- und Pendelleuchten aus Tyvek®. Die Stehleuchten haben einen inneren Harzsockel und eine Metallschirmstruktur. Die Pendelleuchten verfügen über eine Metallschirmstruktur, mit einer in Tyvek® verkleideten Deckenrosette und einem Kabel.



Materiale / Material



Tyvek

Pajama 91 → p. 036, 037, 106

Pajama 92 → p. 047

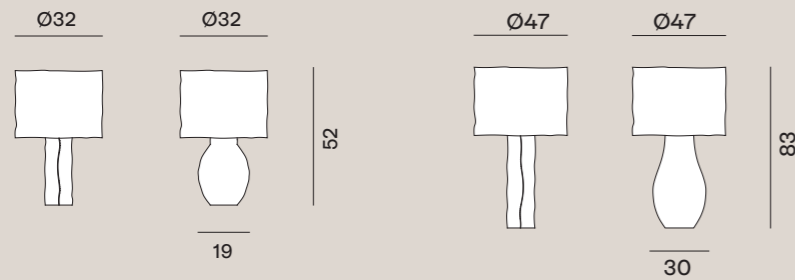

Pajama 94 → p. 060-061, 099, 112

Pajama 95 → p. 012, 064-065

Pajama 96 → p. 026-027, 029

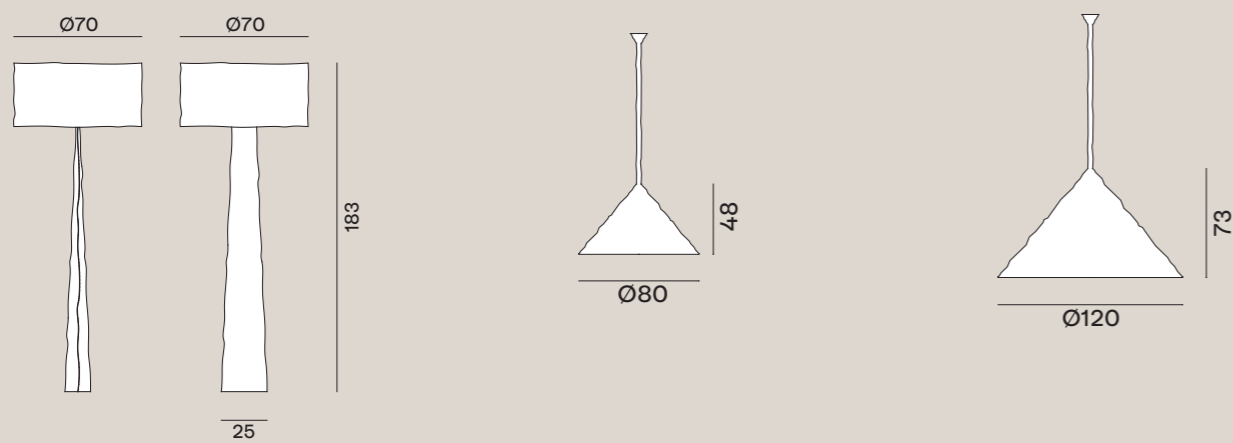

I. Grazie alla sua duttilità, il midollino ha permesso di reinterpretare una serie di complementi d'arredo: lampade e tavolini realizzati in midollino intrecciato a mano. La bellezza dell'intreccio in fibra naturale unita ad un design originale dà vita ad una collezione ideale per completare l'arredo di ogni ambiente della casa, conferendogli carattere e unicità.

E. Thanks to its flexibility, wicker lends itself to the reinterpretation of a series of furnishing accessories: lamps and side tables made of hand-woven wicker. The beauty of the natural fibre weave, combined with an original design, gives rise to a collection that is ideal for completing the décor of any interior, adding character and a sense of uniqueness.

F. Grâce à sa ductilité, l'osier a permis de réinterpréter une série d'articles d'ameublement : lampes et tables basses en osier tressé à la main. La beauté du tissage en fibres naturelles associée à un design original donne vie à une collection idéale pour compléter l'ameublement de n'importe quel espace de la maison, en lui conférant caractère et unicité.

D. Dank seiner Anpassungsfähigkeit hat das Peddigrohr zu einer Neuinterpretation mehrerer Einrichtungsgegenstände geführt: Lampen und Beistelltische aus von Hand geflochtenem Peddigrohr. Die Schönheit von geflochtenen Naturfasern in einem originellen Design haucht einer Kollektion Leben ein, die ideal ist, um jeden Raum im Haus auszustatten und ihm einen einzigartigen Charakter zu verleihen.



Finiture Midollino / Wicker Finishes

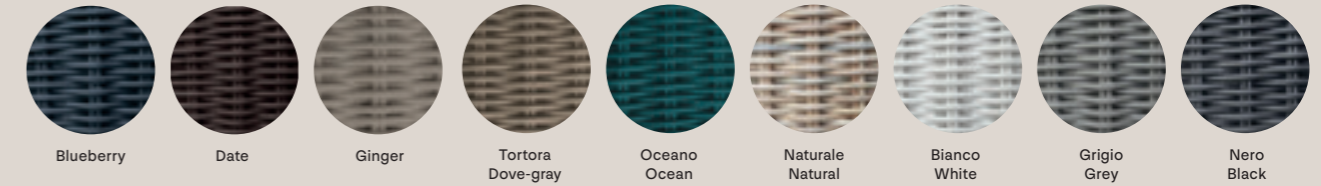

Bolla S

Bolla M → p. 012

Bolla L → p. 033

Bolla XL → p. 033

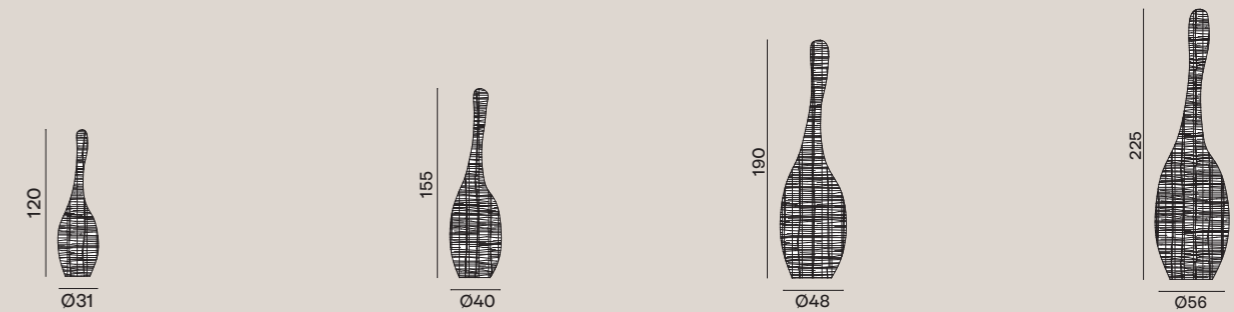

Bolla 10 → p. 008, 010

Bolla 12 → p. 008, 012, 091

Bolla 15 → p. 008, 011

Spin 95 → p. 052

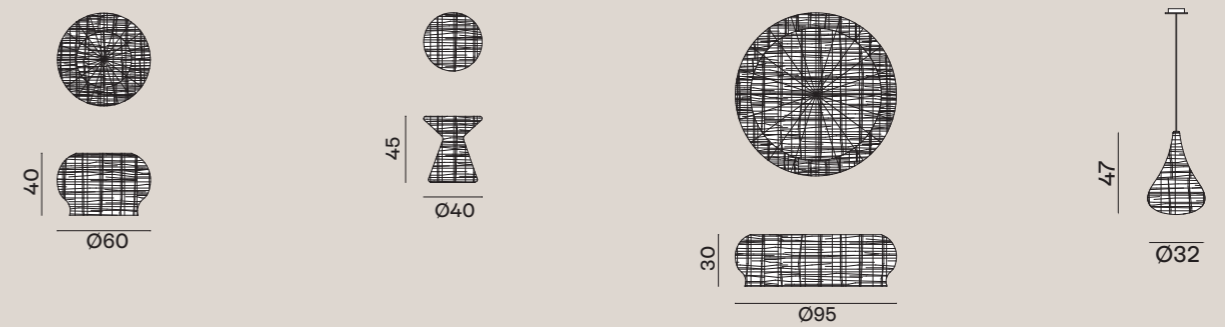

Spin 96 → p. 120-121

Spin S → p. 057, 091

Spin M → p. 057, 074, 091

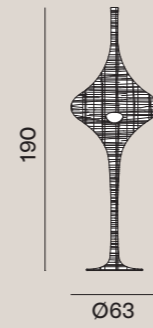
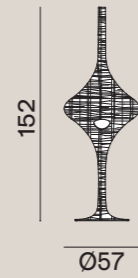
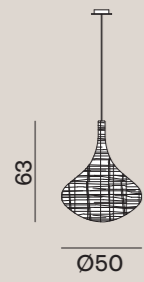

Spin L → p. 074

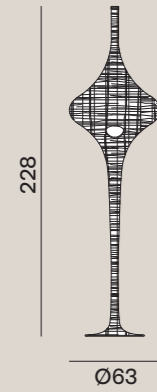

I. Dal forte impatto decorativo, le collezioni Brass e Silver uniscono la duttilità dell'ottone alla sua capacità di impreziosire ogni interno grazie ai suoi riflessi luminosi. Le lampade a sospensione hanno una forma leggera di grande appeal visivo: un leggero disco di ottone che fluttua nell'aria riflettendo la luce in maniera poetica e suggestiva. Completano la collezione Brass anche una serie di piccoli tavoli e tavolini dall'immagine scultorea e con il piano in versione ottone, alluminio o cemento bianco finitura Pearl, per riflessi caldi e dorati, freddi e argentei, o più materici e luminosi.

E. With a strong decorative impact, the Brass and Silver collections combine the ductility of brass with its ability to embellish any interior thanks to its luminous reflections. The pendant lamps have a light shape of great visual appeal: a light brass disk that floats in the air reflecting the light in a poetic and evocative way. The Brass collection is completed by a series of small tables and side tables with a sculptural appearance, featuring tops in brass, aluminum or white concrete with Pearl finish, creating warm golden reflections, cool silvery tones, or a more material and luminous effect.

F. Avec leur fort impact décoratif, les collections Brass et Silver allient la ductilité du laiton à sa capacité à embellir n'importe quel intérieur grâce à ses reflets lumineux. Les lampes à suspension présentent une forme légère au grand attrait visuel : un disque en laiton léger qui flotte dans l'air et reflète la lumière de manière poétique et suggestiva. La collection Brass est complétée par une série de petites tables et tables basses à l'image sculpturale, avec des plateaux en laiton, en aluminium ou en béton blanc finition Pearl, offrant des reflets chauds et dorés, froids et argentés, ou un rendu plus matériel et lumineux.

D. Die sehr dekorativen Kollektionen Brass und Silver verbinden die Anpassungsfähigkeit von Messing mit seiner Fähigkeit, alle Innenräume mit Lichtreflexen zu verschönern. Die Hängelampen haben eine leichte Form mit großem visuellen Charme: eine leichte Messingscheibe schwebt in der Luft und reflektiert das Licht auf poetische und stimmungsvolle Art. Ergänzt wird die Kollektion Brass durch eine Serie kleiner Tische und Beistelltische mit skulpturalem Erscheinungsbild, ausgestattet mit Tischplatten aus Messing, Aluminium oder weißem Beton in Pearl-Finish, die warme goldene Reflexe, kühle silbrige Töne oder eine stärker materielle und lichtvolle Wirkung erzeugen.



Finiture Piano / Top Finishes



Finiture Lampade / Lamp Finishes



Brass 43 → p. 102, 107

Brass 44 → p. 008, 103, 105

Brass 145

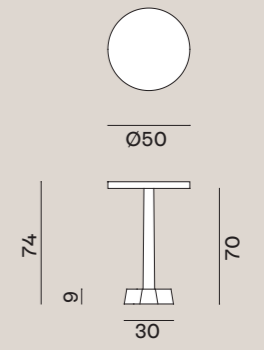
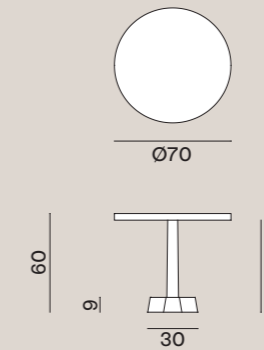
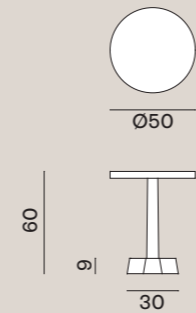

Brass 146 → p. 024, 094, 095

Brass 147 → p. 094

Brass 95

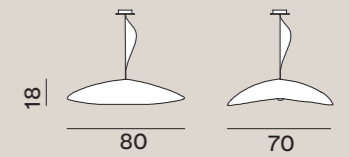
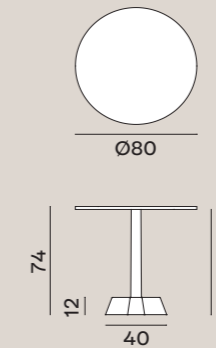
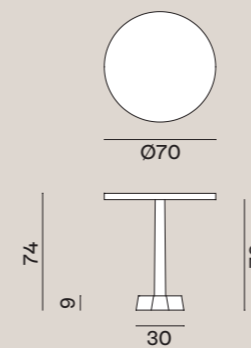

Brass 96 → p. 020-021, 023

Silver 95 → p. 094

Silver 96 → p. 056-057, 078-079

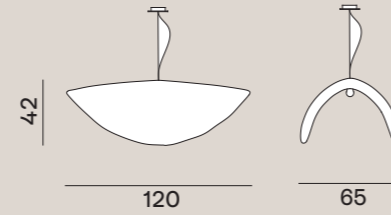
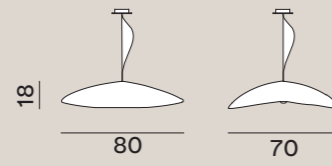
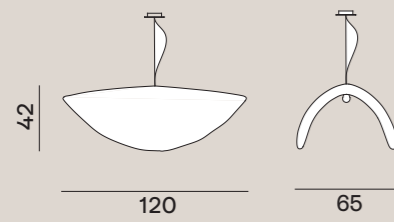

I. Versatile e confortevole, la collezione di sedie Allu combina la leggerezza e l'essenzialità della struttura in alluminio ad un gioco dinamico di texture, creato dall'intreccio in pergamena naturale o grigia. Capace di inserirsi in ogni ambito, dal domestico al contract, Allu racconta la profonda esperienza di Gervasoni nella lavorazione di materiali diversi.

F. Polyvalente et confortable, la collection de chaises Allu allie la légèreté et l'essentialité de la structure en aluminium à un jeu dynamique de textures que crée le tissage en cuir brut naturel ou gris. Capable de s'intégrer à n'importe quel type d'ameublement, qu'il soit domestique ou contract, la ligne Allu raconte la profonde expérience de Gervasoni dans le traitement de différents matériaux.

E. Versatile and comfortable, the Allu chair collection combines the lightness and essentiality of the aluminium structure with a dynamic play of textures, created by the weaving in natural or grey rawhide. Able to fit into any area, from domestic to contract, Allu tells the story of Gervasoni's extensive experience in the processing of different materials.

D. Die vielseitige und bequeme Stuhlkollektion Allu verbindet die Leichtigkeit und Wesentlichkeit des Aluminiumgestells mit einem dynamischen Spiel von Texturen, das durch das natürliche oder graue Rohledergerflecht entsteht. Allu fügt sich mühelos in jede Umgebung ein, vom Wohn- bis zum Objektbereich, und zeugt von Gervasonis großer Erfahrung bei der Verarbeitung verschiedener Materialien.



Intreccio / Weaving



Allu 23 I → p. 054, 055

Allu 24 I

Allu 223 I → p. 110-111

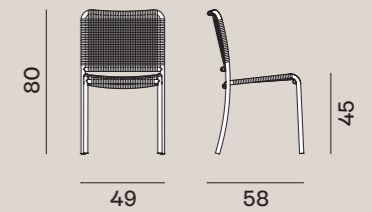
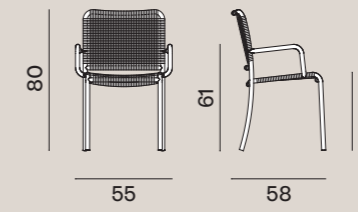
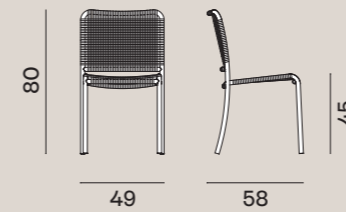

Allu 224 I → p. 110-111, 112

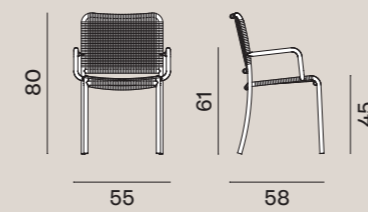

I. La collezione Mae è composta da tavoli ovali e tondi e da una poltroncina dining coordinata. I tavoli presentano una base conica dalla presenza scultorea ed essenziale, con struttura in polimero espanso e piano in MDF, rifiniti in calce-argilla spatolata per una superficie materica, levigata e raffinata.

E. The Mae collection consists of oval and round tables, along with a coordinated dining armchair. The tables feature a sculptural and essential conical base, with a structure in expanded polymer and an MDF top, finished in hand-applied lime-clay for a smooth, refined, and tactile surface.

F. La collection Mae se compose de tables ovales et rondes, ainsi que d'un fauteuil de salle à manger coordonné. Les tables présentent une base conique à la présence sculpturale et essentielle, avec une structure en polymère expansé et un plateau en MDF, finis en chaux-argile spatulée pour une surface lisse, raffinée et tactile.

D. Die Mae Kollektion umfasst ovale und runde Tische sowie einen passenden Dining-Sessel. Die Tische zeichnen sich durch eine konische Basis mit skulpturaler und reduzierter Präsenz aus. Sie verfügen über eine Struktur aus expandiertem Polymer und eine MDF-Tischplatte mit gespachtelter Kalk-Ton-Oberfläche, die eine glatte, edle und haptische Anmutung verleiht.



Finiture / Finishes

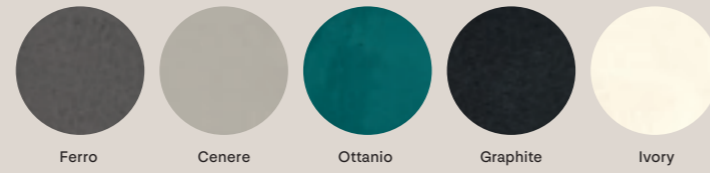

Mae 33 → p. 026-027, 029, 064-065

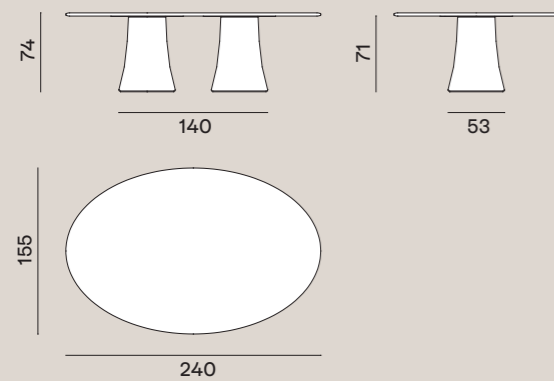

Mae 34 → p. 056-057, 058

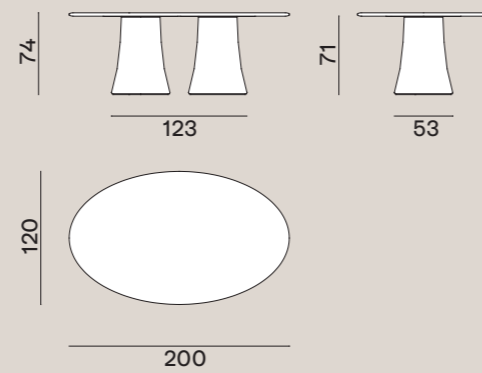

Mae 36 → p. 082-083

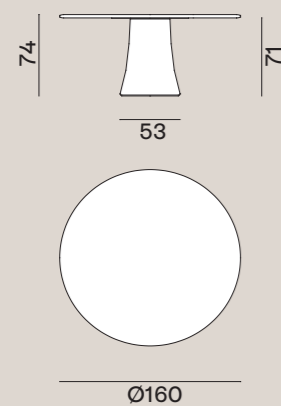

Mae 39

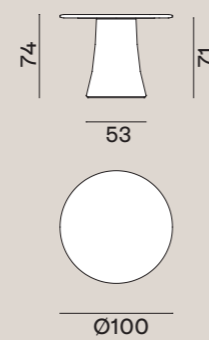

I. La poltroncina Mae è caratterizzata da una struttura in frassino e da una seduta in poliuretano su telaio in legno multistrato cinghiato. Il rivestimento, sfoderabile, è proposto in tessuto trapuntato, che valorizza le superfici e contribuisce a una sensazione di comfort avvolgente e misurato.

E. The Mae armchair features an ash wood structure and a polyurethane seat on a webbed plywood frame. The removable upholstery is available in quilted fabric, enhancing the surfaces and contributing to a balanced, enveloping sense of comfort.

F. Le fauteuil Mae se caractérise par une structure en frêne et une assise en polyuréthane sur châssis en multiplis sanglé. Le revêtement, déhoussable, est proposé en tissu matelassé, qui valorise les surfaces et apporte une sensation de confort enveloppant et mesuré.

D. Der Mae Sessel zeichnet sich durch eine Struktur aus Eschenholz und eine Sitzfläche aus Polyurethan auf einem gegurteten Sperrholzrahmen aus. Der abnehmbare Bezug aus gestepptem Stoff betont die Oberflächen und vermittelt ein ausgewogenes, einladendes Komfortgefühl.

Finiture Legno / Wood Finishes

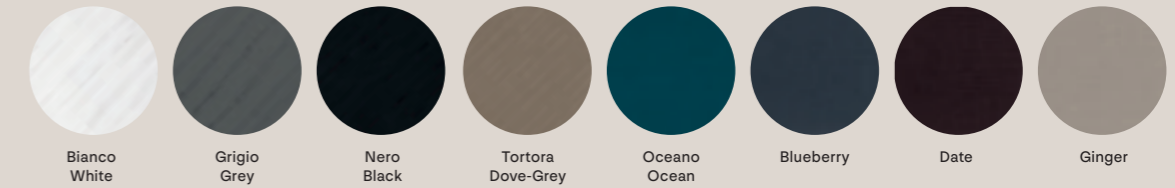

Mae 24 → p. 026-027, 028, 030, 056-057, 059

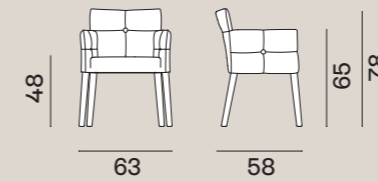

Ghost

Paola Navone

I. Sedia e poltroncina con braccioli. Seduta, schienale e gambe imbottiti in poliuretano espanso. Rivestimento sfoderabile.

F. Chaise et bridge avec assise, dossier et pieds rembourrés, déhoussable.

E. Chair and armchair with upholstered seat, back and feet. Removable cover

D. Stuhl und Armlehnstuhl mit gepolsterten Sitz, Rücken und Beinen, abziehbar.



Ghost 123 → p. 049, 051

Ghost 125 → p. 125 048, 050, 120-121, 122, 123

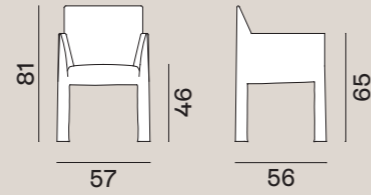
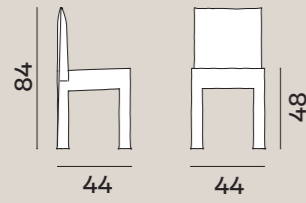

Brick

Paola Navone

I. Tavolo rettangolare, gambe cilindriche tornite a mano in porcellana smaltata con effetto craquelé colore Celadon o in porcellana bianca e sabbia vulcanica con finitura opaca effetto stratificato. Piano in marmo bianco Carrara o in pietra lavica levigata..

F. Table rectangulaire, pieds cylindriques tournés à la main en porcelaine émaillée avec effet craquelé, couleur Céladon, ou en porcelaine blanche et sable volcanique avec finition mate stratifiée. Plateau en marbre blanc de Carrare ou en pierre de lave polie.

E. Rectangular table, hand-turned cylindrical legs in glazed porcelain with craquelé effect, Celadon colour, or in white porcelain and volcanic sand with matt layered effect finish. Top in white Carrara marble or polished lava stone.

D. Rechteckiger Tisch, handgedrehte zylindrischen Beine aus glasiertem Porzellan mit Craquelé-Effekt, Farbe Celadon, oder aus weißem Porzellan und Vulkansand mit mattem Schichteffekt. Platte aus weißem Carrara-Marmor oder poliertem Lavastein.



Piano / Top

Gambe / Legs

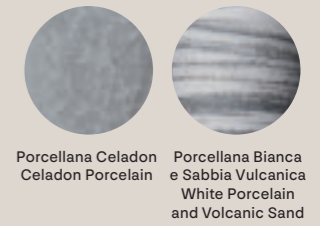

Brick 143 → p. 078-079, 081, 110-111

Brick 144

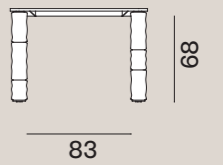
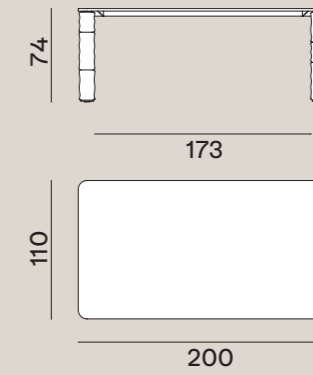
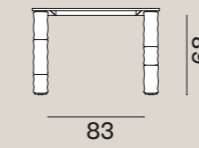
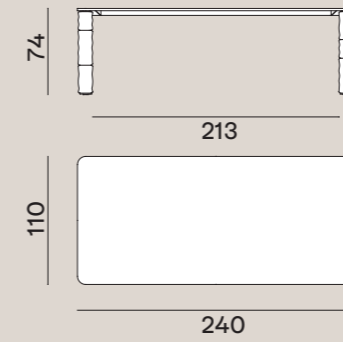



Abacus by Categories

Armchairs

Loll 01 → p. 118, 119

Loll 05 → p. 012, 013, 036

Loll 07 → p. 039, 041, 042-043, 083



Loll 09 → p. 046-047, 063, 071, 073

Nuovola 05 → p. 107, 108, 109

Nuvola 09 → p. 086-087, 089



Chairs

Allu 223 I, 23 I → p. 110-111

Allu 224 I, 24 I → p. 110-111, 112

Ghost 123 → p. 049, 051



Ghost 125 → p. 048, 050, 120-121, 123, 110-111

Loll 223 → p. 032-033, 034, 083, 095

Loll 224 → p. 082, 084, 085, 095

Loll 225 → p. 064-065, 067, 078-079, 094



Loll 226 → p. 078-079, 094

Mae 24 → p. 026-027, 030, 056-057

Next 25 → p. 024, 025



Sofas

Loll 10



Loll 12 → p. 052-053

Loll 14 → p. 011



Loll 16 → p. 020, 022, 023

Loll Modulare → p. 008, 014, 060, 070, 074, 090, 098, 102, 115



Nuvola 12 → p. 086-087, 088, 106-107



Tables & Desks

Brass 145

Brass 146 → p. 024, 094, 095



Brass 147 → p. 094



Brick 143 → p. 078-079, 081, 110-111

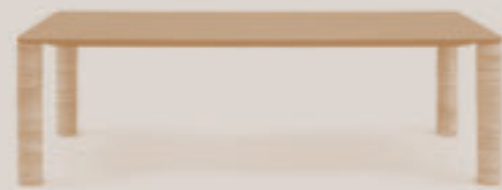

Next 141, 142, 144 → p. 046-047, 052-053



Next 147 → p. 114-115



Next 148 → p. 114-115



Mae 33, 34 → p. 026-027, 029, 056-057, 058, 064-065



Mae 36 → p. 082-083



Beds

Loll 80 → p. 038-039, 040



Next 136 → p. 048-049



Next 137 → p. 120-121



Complements

Bolla 10 → p. 008, 010



Bolla 12 → p. 008, 012, 091



Bolla 15 → p. 008, 011



Next 236 → p. 032-033, 035



Kira 97 → p. 029, 079, 098-099



Kira 98 → p. 011, 086



Heiko 41 → p. 039, 042



Heiko 42



Coffee Tables

Brass 43 → p. 102, 107



Brass 44 → p. 008, 103, 105



Kira 43, 44, 46 → p. 062, 063, 073, 074, 100, 118



Heiko 43 → p. 060, 086



Heiko 44 → p. 060, 086, 098, 106



Log S, M, L → p. 053, 083, 086



Sweet 97, 98 → p. 053, 070, 095



Ottomans

Loll 08 → p. 071, 073



Loll 29 → p. 021



Loll 128 → p. 021, 053, 061, 091



Lightings

Bolla S, M, L, XL → p. 012, 033



Brass 95 / Silver 95 → p. 094



Brass 96 / Silver 96 → p. 020, 056, 078



Pajama 91 → p. 036, 037, 106



Pajama 92 → p. 047



Pajama 94 → p. 060, 099, 112



Pajama 95, 96 → p. 012, 026, 064



Spin 95 → p. 052



Spin 96 → p. 120-121



Spin S, M, L → p. 057, 074, 091



Sweet 91 → p. 038



Sweet 95 → p. 032-033



Sweet 96 → p. 082-083



Rugs

Next 998



Next 999 → p. 026, 038, 058, 074, 110



Credits:

Concept + Design:
Choice–Studio

Product design:
Paola Navone
Marco Acerbis
Marta Giardini
René Barba
Michael Sodeau

Photo:
Max Rommel

Styling:
Ilaria Baccocchi Studio

Colour separation:
Lucegroup.it

Printed in Italy:
Grafiche Antiga
Gennaio 2026

Gervasoni Spa
Viale del Lavoro, 88
33050 Pavia di Udine, Italy
ph. +39 0432 656611
info@gervasoni1882.com
www.gervasoni1882.com

Thanks to:

Alberto Levi Gallery
albertolevi.com

Contardi
contardi-italia.it

Ilaria Franza
ilariafranza.com

Dainelli Studio
dainellistudio.it

Golran
golran.com

Illulian
illulian.com

KDLN
kdln.it

Luceplan
luceplan.com

Martinelli Luce
martinelliluce.it

Mohebban
mohebbanmilano.com

Penta Light
pentalight.com

Tai Ping Carpets
taipingcarpets.com

TOOY Lighting
tooy.it

GERVASONI®
1882

Gervasoni spa è dotata di un Sistema di Qualità Certificato UNI EN ISO 9001, di un Sistema per la gestione della Sicurezza e della Salute dei lavoratori Certificato ISO 45001 e di un Sistema di Gestione Ambientale Certificato UNI EN ISO 14001 / Gervasoni spa is certified to: UNI EN ISO 9001 Company Quality System Certification, ISO 45001 Certification for Health and Safety Management Systems and UNI EN ISO 14001 Environmental Management System Certification.



PART OF

DEXELANCE



CATLOLL26

© Copyright 2026 Gervasoni S.p.A.
Tutti i diritti riservati

